

Data sheet

Liquid Level Alarms, Safety Control, Liquid Level Regulator

RT 280A, RT 281A

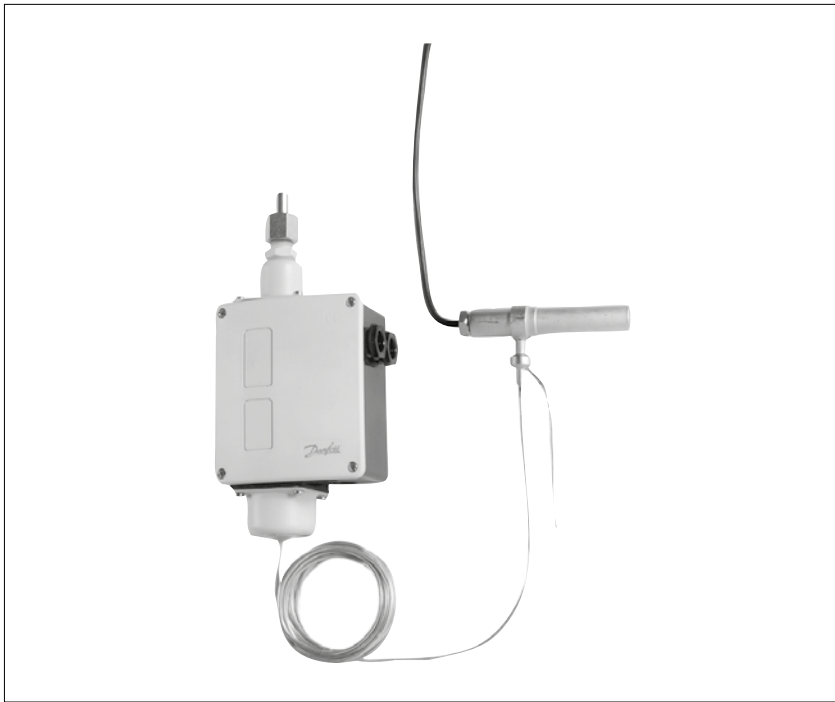

RT 280A and RT 281A are primarily used as liquid level alarms and safety switches to prevent too high a liquid level in liquid separators.

Secondarily, RT 280A and RT 281A can be used as liquid level regulators where a liquid level differential of up to ± 40 mm can be permitted.

When used as safety switches, RT 280A and RT 281A ensure that the max. permissible refrigerant level in flooded evaporators, pump tanks or liquid separators is not exceeded.

As liquid level regulators, RT 280A and RT 281A maintain a constant average refrigerant level in flooded evaporators, pump tanks or liquid separators.

Features

- Waterproof versions, enclosure IP66
- Single pole changeover switch (SPDT) suitable for AC / DC loads
- Interchangeable contact system

Approvals

CE-approved according to
EN 60947-4, -1 EN 60947-5, -1

Meets the requirements of VDE 0660 (VDE:
Verband Deutscher Elektrotechniker)

Technical data

Refrigerants	R717 (NH ₃), R22 and R502 "For other refrigerants, please contact Danfoss."	
Operating ranges for RT 280A	R12	-50 – 10 °C
	R22 and R717 (NH ₃)	-50 – 0 °C
	R502	-65 – -5 °C
Operating ranges for RT 281A	R22 and R717 (NH ₃)	-30 – 20 °C
Ambient temperature	-50 – 70 °C	
Switch	Single pole changeover switch (SPDT), code no. 017-403066	
Contact load	Alternating current	AC1: 10 A, 400 V
		AC3: 4 A, 400 V ¹⁾
		AC15: 3 A, 400 V
	Direct current	DC13: 12 W, 220 V
Weight	2.0 kg	
Enclosure	IP66 to IEC 529.	
Pressure connection	G 3/8 A with ø 6.5 / ø 10 mm weld nipple	
Max. working pressure	PB = 22 bar	
Max. test pressure	Pe = 25 bar	
Thermostatic element	Adsorption charge	
	3 m capillary tube	
	Max. permissible bulb temperature: 80 °C	
Bulb with electric heater	10 W heater for 24 V DC or AC The heater must be constantly energised whilst the system is in operation. 1.5 m connection cable.	

¹⁾ Max. short-time AC3 current: 28 A

Liquid level differential

With a steady liquid level and a liquid level variation rate of max. 15 mm/min, the differential will be approx. 10 mm on a rise in level and approx. 20 mm on a fall in level. In unfavourable operating conditions, differentials of approx. 20 mm on a rise in level and approx. 60 mm on a fall in level must be expected.

Materials

Gaskets are non-asbestos.

Ordering

RT 280A code no. **017D004066**
RT 281A code no. **017D004666**

Design / Function

- 3. Pressure connection
- 4. Bellows element
- 5. Setting disc
- 9. Scale
- 10. Loop terminal
- 11. Pg 13.5 screwed cable entry
- 12. Spring
- 14. Terminals
- 15. Spindle
- 16. Switch (17-4030)
- 17. Upper guide bush
- 18. Contact arm
- 20. Lower guide bush
- 38. Earth terminal

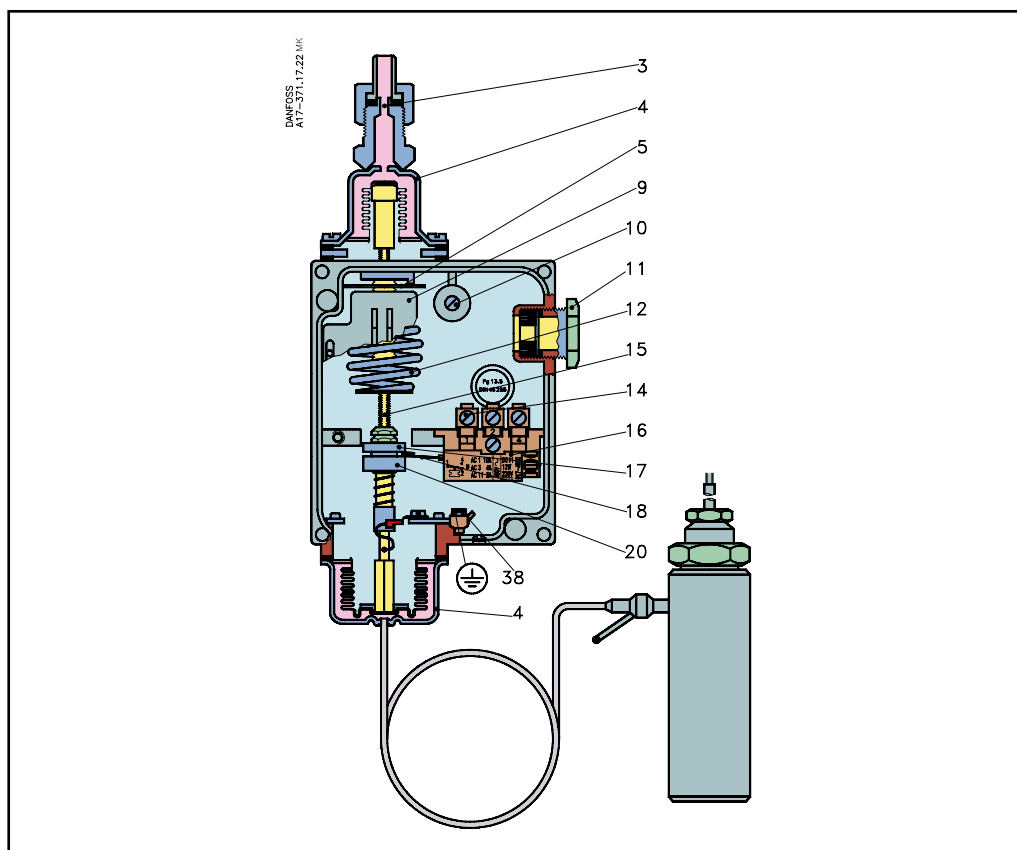

RT 280A and RT 281A units are based on RT 260A. The lower element is thermal and has an electrically heated bulb. As stated, the units are primarily for use as liquid level alarms and safety switches. In designing the units, emphasis was placed on the failsafe function. In the event of a defect in the thermal element, the compressor is stopped and liquid injection cut off. Restart is only possible after the defect has been rectified.

This also applies in the case of loss of charge, for example if the capillary tube or heating element in the bulb is damaged, or if current to the heating element falls. The element heating or cooling signal is compared to the reference pressure and then converted to an electric on / off impulse. The regulating principle is based on the heat conduction difference between the liquid and vapour phases of the refrigerant.

Note:

If the evaporating temperature, and with it the reference pressure, is higher than the max. regulation range temperature, the unit will react as though the liquid level in the liquid container was too high.

**Dimensions [mm] and
weights [kg]**

