

APPION
Star Performance

G5TwinTM
CYLINDER / CONDENSER

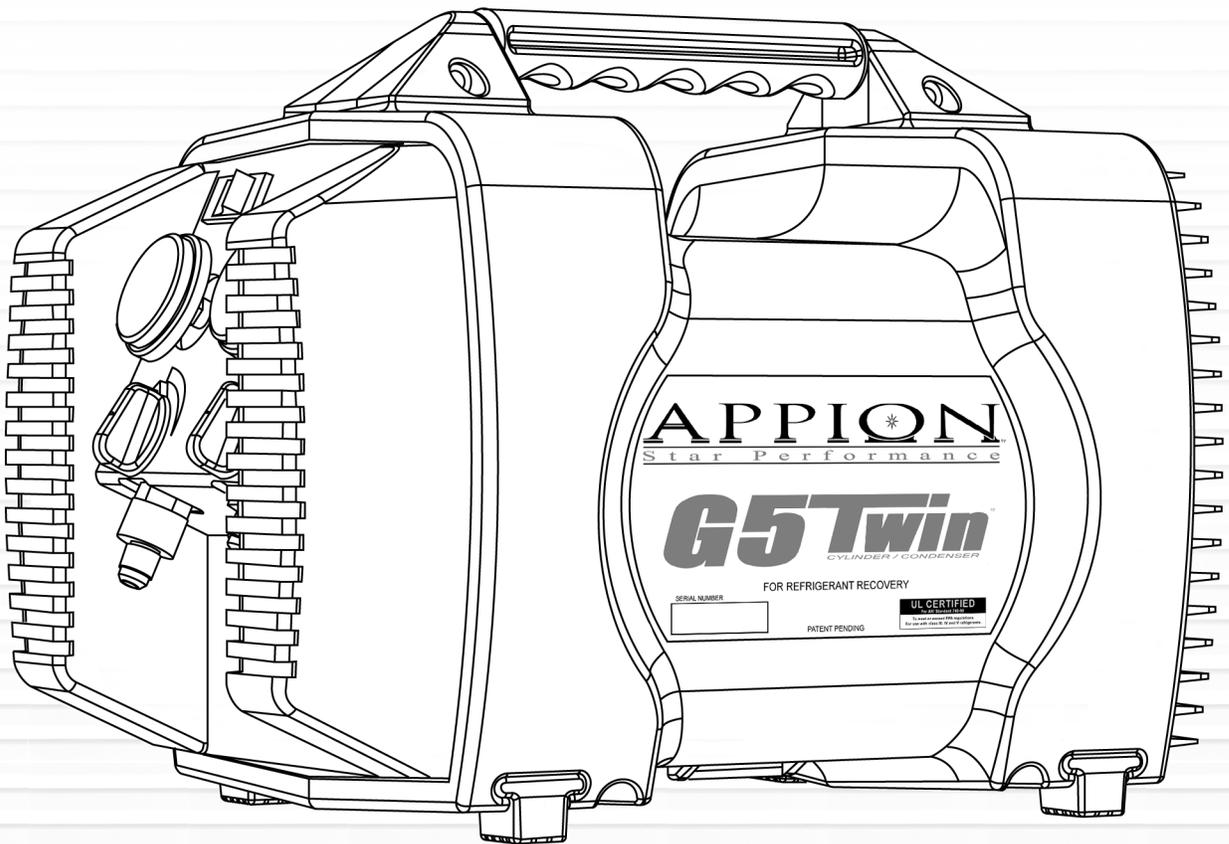

OPERATION MANUAL

Table of Contents

<u>Warnings and Safety Information</u>	3
Refrigerant Storage Container Safety	3
<u>Machine Usage</u>	4
Standard Recovery Procedure	4
Push/Pull Recovery Procedure (For Bulk Liquid Refrigerant)	5
Tank Cooling Procedure (Optional)	6
Alternative Cooling Setup (Optional)	6
Purging Non-Condensables from Storage Tanks	6
Changing Refrigerants	7
<u>Helpful Hints</u>	7
Helpful Hints Continued	8
<u>Care and Maintenance</u>	8
Screen Cleaning and Replacement	8
Troubleshooting Guide	9
Electrical Diagrams	10
Refrigerant Flow Diagram	11
Parts Diagram	11
Manufacturers Limited Warranty	12

Warnings and Safety Information

This machine is for use by trained and certified professionals only.

Always wear gloves and eye protection when using this machine or handling refrigerants.

Read all Material Safety Data Sheets (MSDS) for any compounds that you are likely to encounter. Failure to do so could lead to injury or death.

To reduce the risk of fire, Extension cords must be at least 12AWG and not longer than 15 ft. This equipment should be used in areas with mechanical ventilation providing at least four air changes per hour, or be located at least 18" above the floor. Do not use this equipment near any spilled or open containers of gasoline or other flammable liquid.

This machine compresses and pumps liquid and vapor refrigerants at high pressures (Pressure cutout set at 550psi +/- 20psi) and can create very dangerous conditions. This machine is to be used only by technicians professionally trained and certified in the safe handling of refrigerants including the recovery process.

Refrigerant Storage Container Safety

Make sure the area you are working in is well ventilated. Breathing refrigerant is hazardous and can cause injury or death.

Use only DOT CFR Title 49 or UL approved storage containers for recovered refrigerant.

Refrigerant recovery cylinders are designed for different pressures. Do not exceed the working pressure for the cylinder that you are using.

Never overfill storage tanks. Safety codes require that tanks not be filled with liquid to over 80% capacity. Refrigerant expands when heated, and tanks may explode if overfilled.

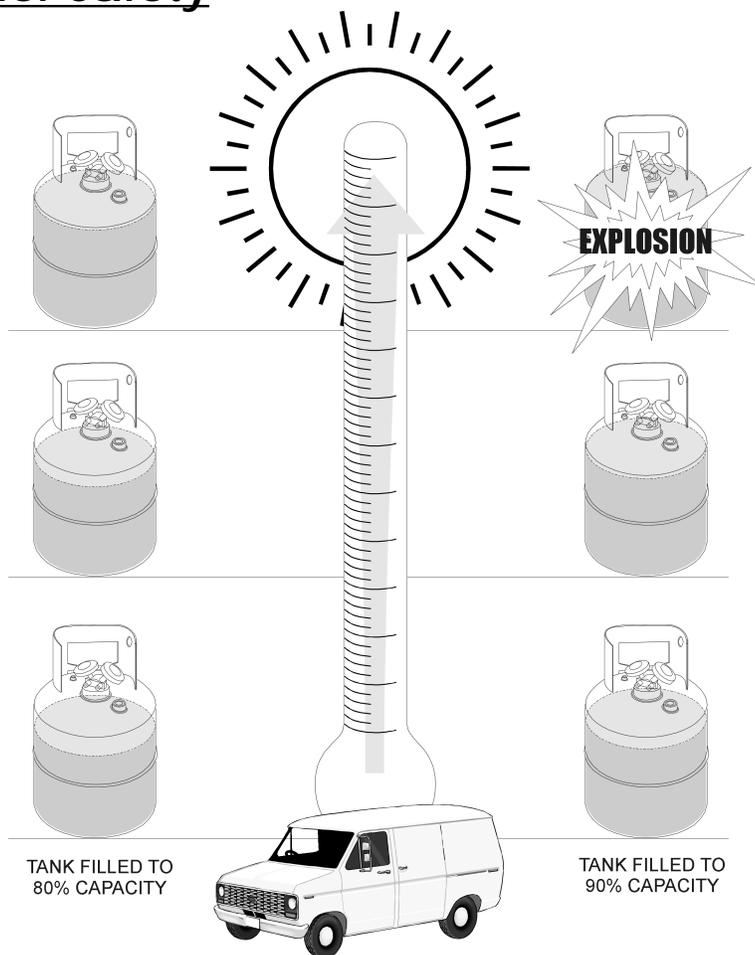

OVERFILLED TANKS CAN EXPLODE DUE TO LIQUID REFRIGERANT EXPANDING WHEN HEATED

Machine Usage

Caution: Always use a grounded 3-prong outlet.

Caution: Always open valves slowly for safety and to check for leaks.

The Appion G5Twin has an internal 550 psi pressure shut off switch to protect the machine from damage. This does not prevent tank overflow.

To Maximize recovery speeds: Use 3/8 inch hoses in all locations with the input hose to G5 Twin being the most important for maximum throughput. For push pull be sure to use a 3/8 inch hose (for the liquid) from the system to the tank and a 3/8 inch hose from the vapor port of the tank to the input of the G5 Twin (for maximum throughput). If the refrigerant is clean, remove all filters and screens for maximum production of both liquid and vapor refrigerant. When using 3/8 inch hoses for pumping straight liquid, some slight throttling of input valve may be helpful for reducing compressor noise in some conditions although not required. Always use the shortest length of hose possible and remove all “Schrader” type valves and the core depressors from the hoses and port connections as they will noticeably slow the recovery process

For best results, use the tank cooling method to lower the head pressure on the recovery tank to get the deepest final vacuum. **Note:** This will only work if there is already liquid in the tank. If there is no liquid in the tank, use a tank that has been fully evacuated.

Standard Recovery Procedure

Note: A scale must be used to avoid overfilling the storage tank.

Note: Use an inline filter when you are pumping dirty refrigerant.

Note: Check that the debris screen (on inlet port) is clean before starting every job. This screen prevents damage to the unit from debris that may get past the inline filter. When pumping dirty refrigerant, this screen may quickly clog and slow the process when used without an inline filter.

1. Setup the machine as shown in the diagram below.
Make sure that all the connections are tight.
 - A. Connect the **AC system High side** to the **Manifold High side**.
 - B. Connect the **AC system Low side** to the **Manifold Low side**.
 - C. Connect the **Manifold center port** to the **Appion G5Twin input port**.
 - D. Connect the **Appion G5Twin output** to the **Recovery Cylinder liquid port**.

2. Connect the Appion G5Twin to a 110V outlet using a 12AWG cord (minimum) and not more than 15 feet long.

3. Make sure the input valve on the Appion G5Twin is closed, this will make it easier for the compressor to start when the power is turned on.

4. Open the liquid port of the Recovery Cylinder and the output valve of the Appion G5Twin.

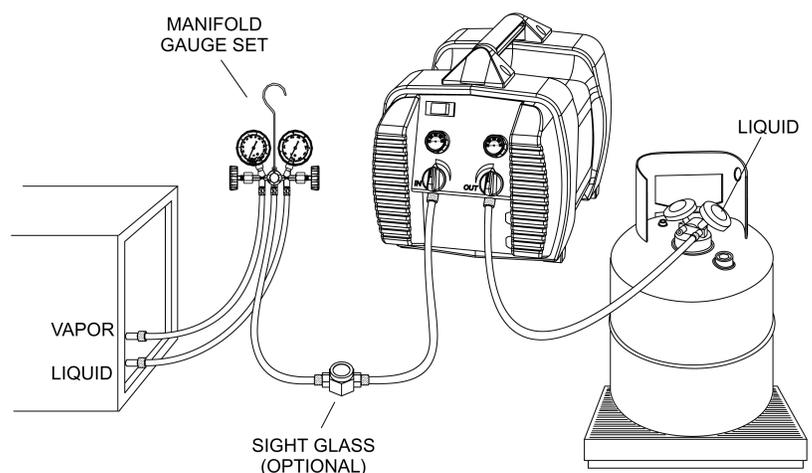

Standard Recovery Procedure Continued

5. Open the liquid port on the Manifold Gauge Set. Removing the liquid first will keep the recovery time to a minimum.
6. Turn on the Appion G5Twin with the On/Off switch on the front panel. The compressor and fan should start.
7. Slowly open the input valve of the Appion G5Twin.
8. When all the liquid has been removed, slowly open the vapor port on the Manifold Gauge Set. Both valves to system should now be fully open to maximize vapor flow.
9. Run the unit until the vacuum required by the EPA is achieved.
10. Close both valves on the Manifold Gauge Set and on the Appion G5Twin.
11. Shut off machine.
12. Close the valves on the Recovery Cylinder and disconnect the hoses.

Push/Pull Recovery Procedure (For Bulk Liquid Refrigerant)

Note: A scale must be used to avoid overfilling the storage tank.

The Push/Pull method is useful for recovering large amounts of liquid from a system. This will only work on large systems where the liquid can be accessed easily. Do not attempt this on systems that contain less than 15 lbs. of refrigerant unless it has a receiver tank or it may not work correctly.

Caution: Once the siphoning starts, it can continue to fill the tank even when the machine has been shut off. To avoid overfilling, you must be sure to close all valves on the tank and system when you are finished.

1. Setup the machine as shown in the diagram below.
Make sure that all the connections are tight.
 - A. Connect the **System vapor port** to the **Appion G5Twin output port**.
 - B. Connect the **System liquid port** to the **Recovery Tank liquid port**.
 - C. Connect the **Appion G5Twin input port** to the **Recovery Tank vapor port**.

Note: Keep valves on tank and system closed at this time.

2. Slowly open valves on the Appion G5Twin.
3. Switch on the power to the Appion G5Twin.
4. Slowly open the valves on the tank and system. The liquid should now begin to be pulled out of the system. You can monitor the progress with an inline sight glass.

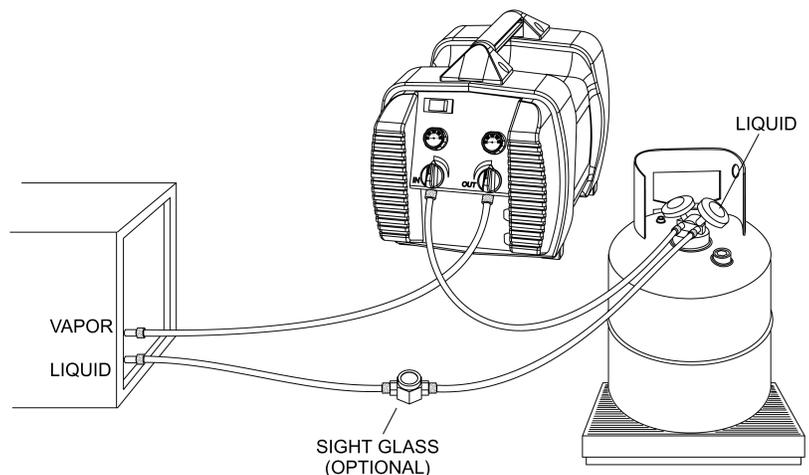

Push/Pull Recovery Procedure Continued

- When all the liquid has been siphoned off, turn off the Appion G5Twin and close all the valves.
- You can now proceed to remove the remaining vapor using the standard recovery procedure.

Tank Cooling Procedure (Optional)

In order for this procedure to work, you must have at least 5 lbs. of liquid refrigerant in the storage tank.

- Connect the hoses as shown.
 - Connect the **Appion G5Twin input** to the **Recovery Cylinder vapor port**.
 - Connect the **Appion G5Twin output** to the **Recovery Cylinder liquid port**.
- Open all valves.
- Start Machine.
- Throttle the output valve so that the output pressure is at least 100 psi greater (but never greater than 300 psi) than the input pressure.
- Run until the tank is cold.

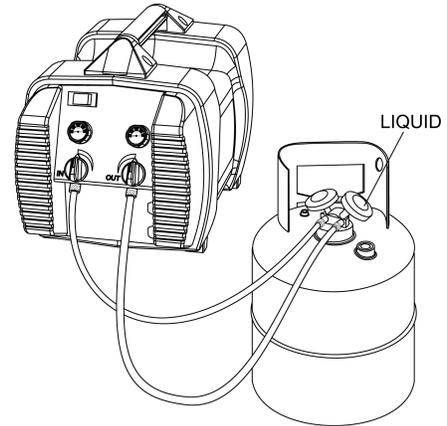

Alternative Cooling Setup (Optional)

By setting up your equipment as shown here, it is possible to cool the tank during the recovery procedure if necessary.

Normal Recovery:

- Tank vapor valve - Closed

Tank Cooling:

- Tank vapor valve - Open
- Manifold Gauge Set - Both Closed
- Follow steps 3-5 above to cool tank

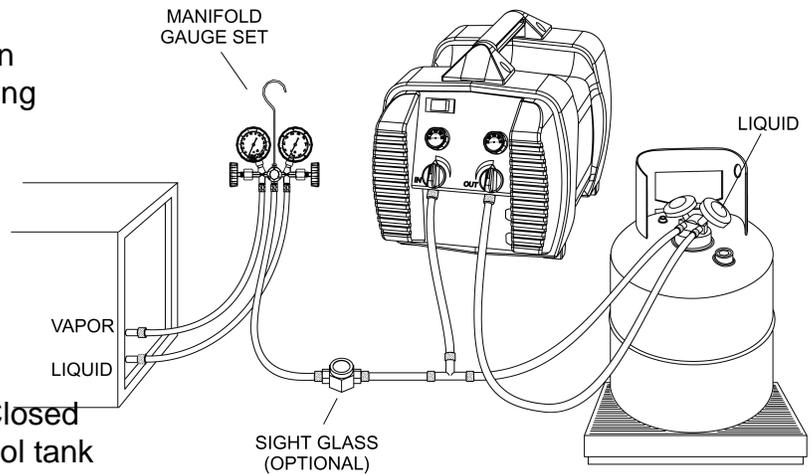

Purging Non-Condensables from Storage Tanks

The tank must be left undisturbed for at least 24 hours so that all of the air will rise to the top.

Connect a Manifold Gauge Set to the tank and check the pressure at the vapor port.

Look up the refrigerant you are using on a Refrigerant Temperature/Pressure chart and use the ambient air temperature to determine what the tank pressure should be. If the tank pressure is higher than the pressure on the chart, Slowly open the vapor port and let the excess pressure bleed off until it is about 5 psi above the pressure on the chart.

Close the valves and let the tank stand still for 10 minutes. Repeat if necessary.

Changing Refrigerants

When switching between different types of refrigerant, any refrigerant remaining in the recovery machine should be drawn into a deeply evacuated cylinder before switching. Then, to prevent any cross-contamination, it is recommended that a vacuum pump be connected to the output of the Appion G5 Twin (the input should be kept closed) and used to completely evacuate the machine. When you start the second refrigerant after evacuating the recovery machine, open the input valve slowly to prevent the liquid from rushing into the evacuated unit.

Helpful Hints

In just a few years, refrigerant recovery has come a long way. At first glance, it's simply the process of taking refrigerant out of a system and putting it into a storage tank. However, this simple process can rapidly become difficult and time consuming if a few things are overlooked. What follows are some notes and guidelines that we have learned over the years that can help you save time and make the job easier.

The first thing you need to do is determine the quantity and type of refrigerant that is being used in the system you are working on. Use a tank that is DOT approved for the high pressures that are present with R410a. If the system is a burnout, you will need to use a special tank marked as containing burnout and other unidentified gases and you must use extra filtration before recovery. This extra filtration is to protect your equipment from corrosion caused by acids that may be present.

If the gas in the system is fairly clean or new, then you should use a clean, new tank. If the refrigerant is going to be reclaimed, or you are going to put the refrigerant back into the system when you are done servicing it, then you should use a tank with the same type of refrigerant in it. One note of caution: If you use many different gases and you only own a single tank, you're asking for trouble with the Environmental Protection Agency (EPA). You should own at least one tank for every type of refrigerant that you will service, and a spare tank for unknown gases and burned out systems.

Plan Ahead

Knowing the quantity of refrigeration that will be recovered is important. Not just for storage requirements, but for the recovery process as well. For example, most systems that contain more than 5 lbs. of refrigerant will probably have areas where liquid can become trapped.

The secret for a quick recovery is to remove all of the liquid first, then getting the remaining vapor out. Unfortunately, many systems out there are not "recovery friendly." Meaning, the access ports are not at the lowest point in the system. If you do regular maintenance on these machines, it would be a wise decision to install access ports at the lowest point possible in the system. This will greatly reduce the time needed to perform the recovery process.

If the system does not have ports at the lowest point in the system, you can use a heat gun to boil off the trapped liquid. Look for areas that have frost or condensation forming on them. This is a good indication that liquid is trapped there. Any trapped liquid will greatly increase the length of time needed to perform the recovery, as can be seen in the diagram below.

If you are sure there is trapped liquid in the system, but are unable to find it, it could be in an area that you are unable to see. If this is the case, turn on the system compressor if possible, and let it run for a couple of seconds. This should move the liquid to another area in the system and in the process it should heat up enough to boil away.

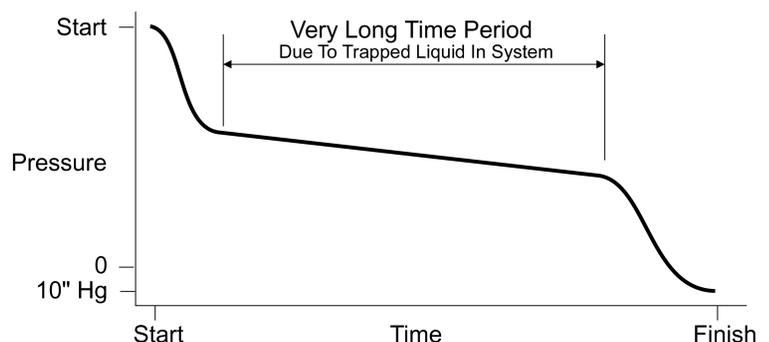

Hoses and Valves

Other important factors in keeping recovery times short are hoses and Schraeder valves. The larger the hoses are, the less restriction there will be on the flow of refrigerant and the recovery times will decrease. Even if you are connecting to 1/4" fittings, using 3/8" hose will decrease the time needed for the recovery process.

Helpful Hints Continued

Also check the rubber seal at the ends of the hose for damage. If the seal becomes worn out and deformed, it can create a restriction when it is tightened up against a flare fitting and the system is being pulled down into a vacuum.

Schraeder valves will also create a restriction and slow down the recovery process. Remove any Schraeder valves from your connections beforehand. You can get a removal tool that will leave the seal intact from most wholesalers. Core depressors, in the end of the hose, should be removed as well. Both of these items, if left in, can cause a short job to take hours to perform.

Imagine trying to drink water through a 1/4-in., 3-ft. long straw. Now pinch the end closed a little bit, and you get an idea of the kind of work your recovery machine is trying to accomplish. Using larger hoses without any restrictions will make it easier on your machine and allow you to finish the job much quicker.

Extension Cords and Low Voltage

Recovery machines will work best when the voltage at the machine (while it is running) is between 115 and 122 volts. A lower voltage can cause difficulty in starting against high pressures. If you have low voltage source power, you may need to relieve the back pressure on the unit to allow it to start.

Check that the voltage coming from the source outlet is adequate. Please note that the circuit could have many other items on it e.g. light fixtures, appliances, or other motors. All of these extra loads on the circuit will cause a lower voltage and reduced performance.

Likewise, long and thin extension cords also starve the motor of necessary voltage and can cause very dangerous overheating of the motor and extension cord.

Care and Maintenance

For dirty refrigerant, always use an inline filter on the input of the Appion G5Twin. Refrigerant acts like a solvent and can collect dirt and debris when it is pumped out of a system. Failure to use a filter will void the warranty on your machine and can cause damage to the compressor.

The Appion G5Twin is equipped from the factory with a debris screen on the input. This is the last line of defense for the recovery machine against any debris that might make it past an inline filter. For best results it is recommended to clean it before each use. If it becomes worn, replace it immediately.

Use extension cords that are at least 12 AWG and less than 15 ft. long. Cords that are longer or have smaller gauge wire, can cause the motor to overheat and could cause a fire.

If the Appion G5Twin is not going to be used for long periods of time, it is recommended that it be cleaned out and purged with dry nitrogen.

Screen Cleaning and Replacement

1. Unscrew housing from input port.
2. Remove screen from housing.
3. Clean screen and housing thoroughly. If the screen is damaged, replace it with a new one.
4. Place clean screen back into housing and screw it back onto input port.

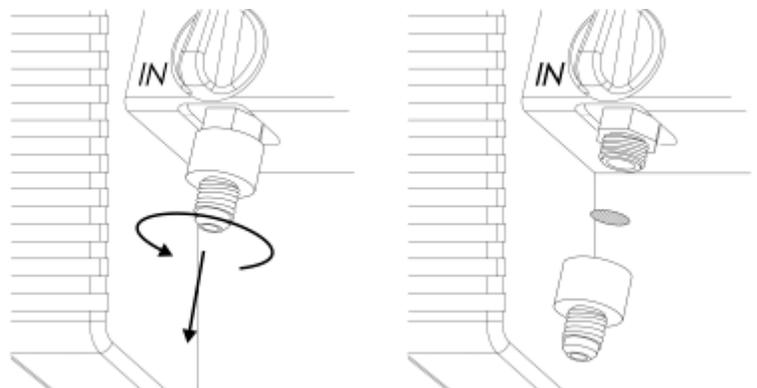

Troubleshooting Guide

Caution: Read all safety information found in this manual and in the Material Safety Data Sheet (MSDS) for the refrigerant you are using before servicing this machine

Symptom	Cause	Solution
Compressor will not start.	Power cord not plugged in or plugged into a bad outlet.	Check power cord, try a different outlet.
	Machine in high pressure shut off.	See symptom below.
	Motor in thermal overload.	Allow motor to cool down.
Compressor tries to start but just makes a buzzing sound.	Low voltage caused by poor source power, small gauge extension cord or too long of an extension cord.	Locate better outlet, reduce length of extension cord and use a heavy gauge cord.
	Too much back pressure on compressor.	Close the input valve to relieve any back pressure on compressor.
Machine pumps into high pressure shut off.	Valve on machine or tank closed.	Check to see if valves are opened and are not plugged.
	Restriction in output hose.	Check hose for blockage and remove any core depressors.
		Relieve pressure from output hose to reset switch.
Pumps liquid slowly.	Restriction in flow.	Use proper size hoses and if possible remove any core depressors and Schraeder valves.
	Trapped liquid in system.	Cycle system compressor for a few seconds to move trapped liquid to another area.

Electrical Diagrams

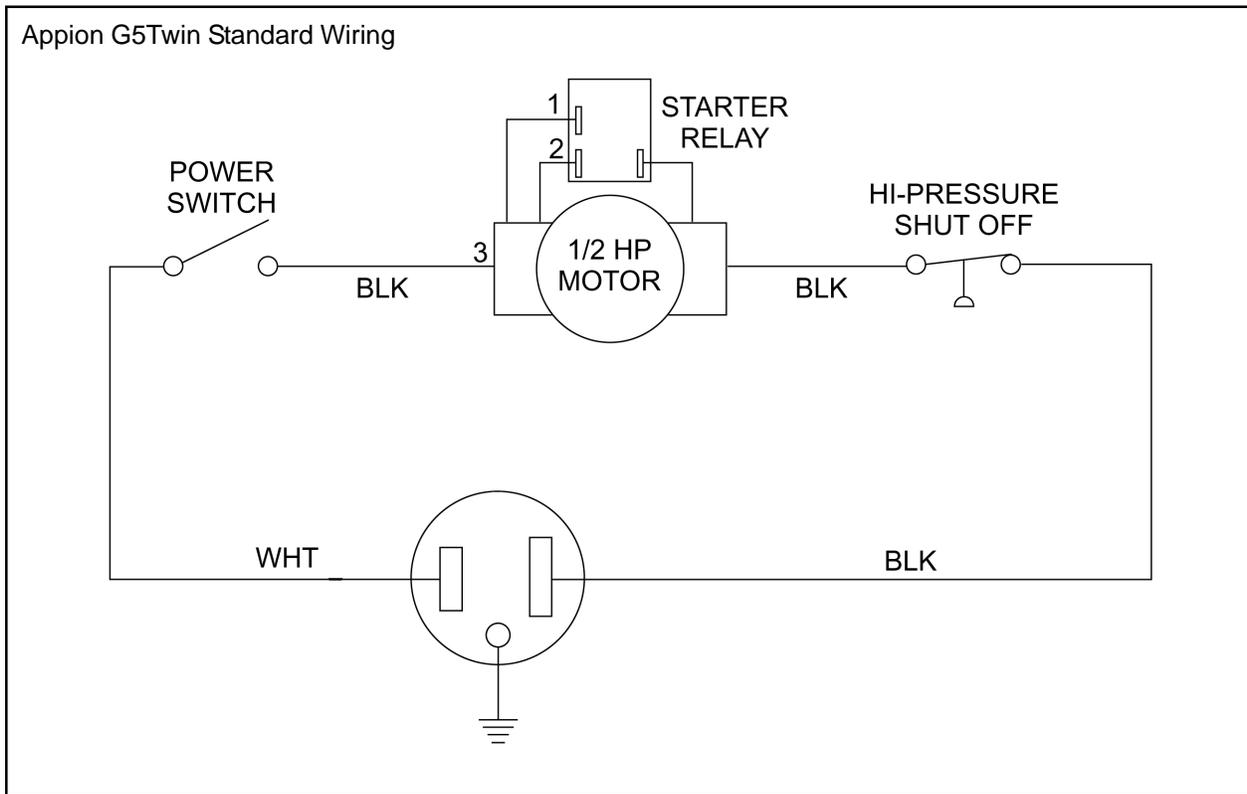

Refrigerant Flow Diagram

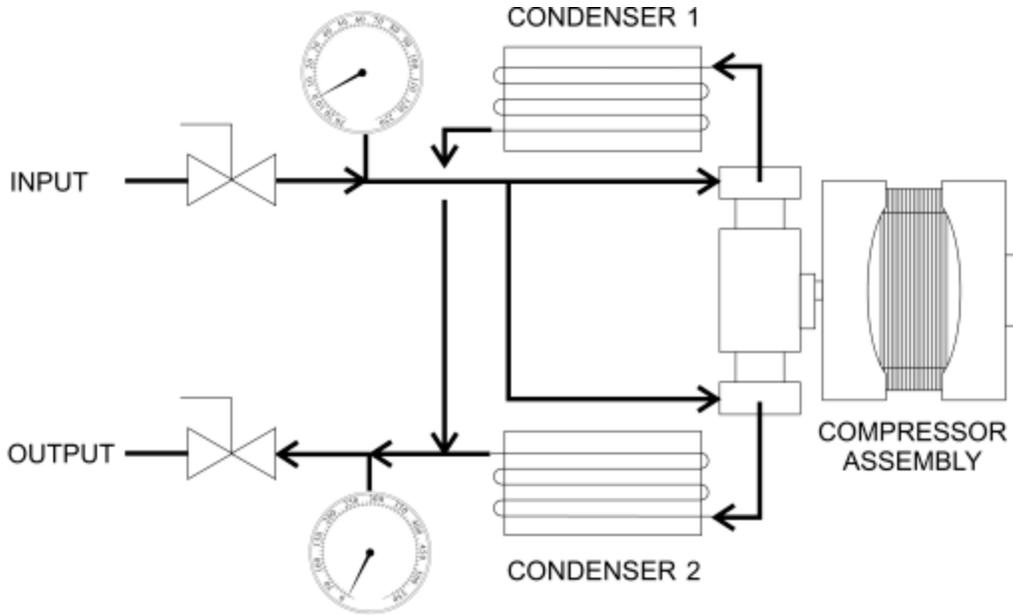

Parts Diagram

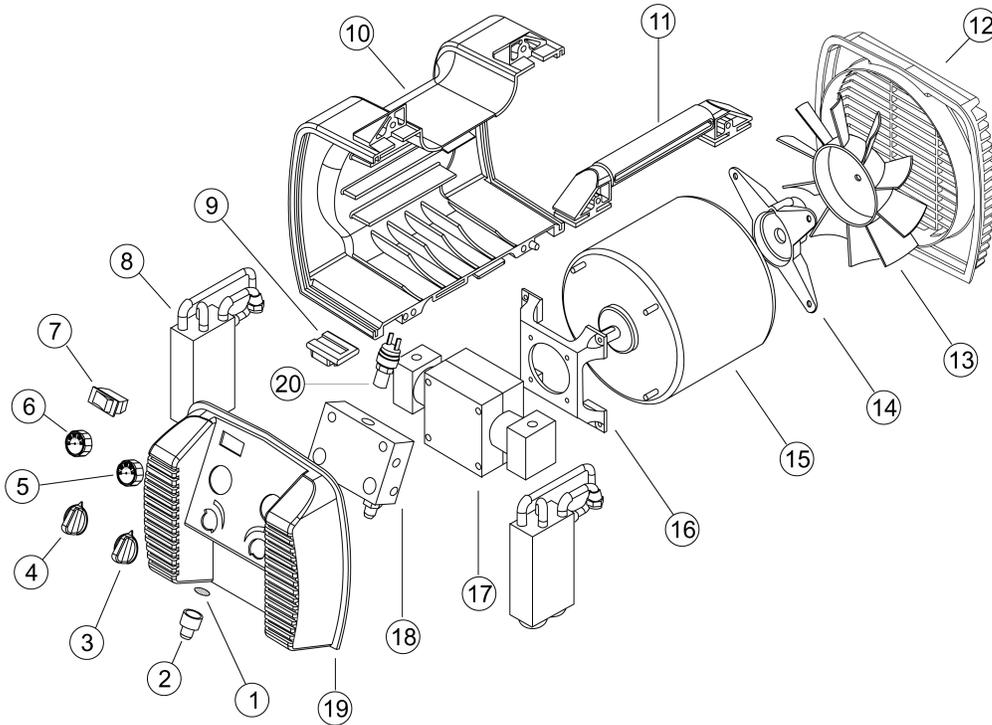

- | | | | |
|-------------------|---------------------|-----------------|----------------------|
| 1. Debris Screen | 6. Input Gauge | 11. Handle | 16. Comp. Mount |
| 2. Screen Housing | 7. Power Switch | 12. Back Panel | 17. Compressor |
| 3. Output Knob | 8. Condenser | 13. Fan | 18. Manifold |
| 4. Input Knob | 9. Foot | 14. Fan Gearbox | 19. Front Panel |
| 5. Output Gauge | 10. Case Side Panel | 15. Motor | 20. Hi-Press. Switch |

*Applion reserves the right to make changes to product and specifications without notice.

Manufacturers Limited Warranty

Manufacturer warrants that the equipment will, under normal and anticipated use, be free from defects in refrigerant related parts for a period of one (1) year from and after the date of shipment, and be free from defects in electrical related parts for a period of ninety (90) days from and after the date of shipment, but in all cases excluding consumables and other matters as hereinafter provided. Labor is NOT covered and shall be the sole cost and responsibility of the Purchaser. The obligation of Manufacturer under this limited warranty is limited to the supplying of parts (excluding consumables and all plastic parts) as hereinabove specifically provided. Parts shall be new or nearly new. Manufacturer assumes no liability for failure in performing its obligations thereunder if failure results, directly or indirectly, from any cause beyond its control, including but not limited to, acts of God, acts of government, floods, fires, shortages of materials, strikes and other labor difficulties or delays or failures of transportation facilities.

Manufacturer shall be liable to replace the applicable parts only if (i) Manufacturer is properly notified by Purchaser upon discovery of the alleged defects, (ii) defective parts are returned to Manufacturer upon authorization with all transportation charges prepaid by Purchaser, (iii) Manufacturer's examination of the parts discloses to its satisfaction that the defects were not caused by the Purchaser or its agents and (iv) the parts are otherwise covered by Manufacturer's limited warranty.

Purchaser shall be responsible to select the means of transportation and bear the cost of inbound and out-bound freight expense associated with any replacement parts, and all risk of loss attendant thereto.

Notwithstanding anything contained in this warranty to the contrary, (i) this limited warranty shall become null and void upon the use of any improper chemicals or in the event any modifications or improper service or installation is performed on the equipment, (ii) this limited warranty does not apply to consumable materials such as, but not limited to, indicator lamps, fuses, all fluids, filters, coatings, seals, etc., and (iii) this limited warranty is applicable only to Purchaser, and no subsequent purchasers of the equipment from Purchaser shall be entitled to any warranty whatsoever from Manufacturer, express or implied.

THIS WARRANTY CONSTITUTES THE SOLE AND EXCLUSIVE WARRANTY OF MANUFACTURER WITH RESPECT TO THE EQUIPMENT, THERE ARE NO OTHER WARRANTIES, EXPRESS OR IMPLIED, AND MANUFACTURER SPECIFICALLY DISCLAIMS ALL OTHER WARRANTIES, EXPRESS OR IMPLIED, INCLUDING (WITHOUT LIMITATION), ANY AND ALL WARRANTIES AS TO THE SUITABILITY OR MERCHANTABILITY OR FITNESS FOR ANY PARTICULAR PURPOSE OF THE EQUIPMENT FURNISHED HERE-

UNDER. THE EXCLUSIVE REMEDY OF PURCHASER AGAINST MANUFACTURER FOR ANY BREACH OF THE FOREGOING LIMITED WARRANTY SHALL BE TO SEEK REPLACEMENT OF THE AFFECTED PARTS.

IN NO EVENT WILL MANUFACTURER'S LIABILITY IN CONNECTION WITH THE EQUIPMENT WHICH IS FOUND TO BE DEFECTIVE EXCEED THE AMOUNTS PAID BY PURCHASER TO APPION HEREUNDER FOR SUCH EQUIPMENT WHICH IS SPECIFICALLY FOUND TO BE DEFECTIVE. THESE LIMITATIONS APPLY TO ALL CAUSES OF ACTION IN THE AGGREGATE, BOTH AT LAW AND IN EQUITY, AND INCLUDING WITHOUT LIMITATION, BREACH OF CONTRACT, BREACH OF WARRANTY, MANUFACTURER NEGLIGENCE, INFRINGEMENT, STRICT LIABILITY, MISREPRESENTATION AND OTHER TORTS AND CONTRACTUAL CLAIMS. EXCEPT FOR THE EXCLUSIVE REMEDY PROVIDED ABOVE FOR MANUFACTURER'S BREACH OF THIS LIMITED WARRANTY, PURCHASER, FOR ITSELF AND ITS SUCCESSORS AND ASSIGNS, HEREBY WAIVES AND RELEASES MANUFACTURER FROM ANY AND ALL OTHER CLAIMS OR CAUSES OF ACTION THEY HAVE AGAINST MANUFACTURER ON ACCOUNT OF OR ASSOCIATED WITH THE EQUIPMENT PURCHASED HEREUNDER OR FOR APPION BREACH OF THIS LIMITED WARRANTY. IN NO EVENT SHALL MANUFACTURER BE LIABLE FOR ANY INDIRECT, SPECIAL, INCIDENTAL, CONSEQUENTIAL OR PUNITIVE DAMAGES, SUCH AS, BUT NOT LIMITED TO, LOSS OF ANTICIPATED PROFITS, LOST SAVINGS, LOST REVENUES, FINES, OR OTHER ECONOMIC LOSS IN CONNECTION WITH OR ARISING OUT OF THE EXISTENCE, FURNISHING, FUNCTIONING OR USE OF ANY ITEM OF EQUIPMENT PROVIDED UNDER THIS AGREEMENT, EVEN IF MANUFACTURER HAS BEEN ADVISED OF THE POSSIBILITY OF SUCH DAMAGES AND/OR SUCH DAMAGES ARE REASONABLE AND/OR FORESEEABLE. FURTHER, PURCHASER FOR ITSELF AND ITS SUCCESSORS AND ASSIGNS, WAIVES AND RELEASES ANY RIGHTS THEY MAY HAVE TO BRING AN ACTION ARISING OR RESULTING FROM THIS AGREEMENT, REGARDLESS OF ITS FORM, MORE THAN FIFTEEN (15) MONTHS AFTER SHIPMENT OF THE AFFECTED EQUIPMENT BY MANUFACTURER TO PURCHASER.

The provisions of this warranty shall supersede any contrary provisions contained in this agreement, any document supplied by Manufacturer to Purchaser or by Purchaser to Manufacturer, or any other agreement, written or oral, between Purchaser and Manufacturer, notwithstanding the fact that the provisions contained in this warranty directly conflict with other terms or provisions of this agreement or such other documents, or that such other documents or agreements were provided, delivered, made or executed subsequent to this agreement unless such agreements are in writing, specifically refer to this agreement, specifically provide that they are amending this and are signed by the President of Manufacturer.

WARRANTY SERVICE

Warranty Service can be obtained by following these steps.

1. Fill out and return the warranty card shown below within 10 days of purchase with a copy of your sales receipt.
2. Contact your wholesaler/Distributor to obtain an Return Goods Authorization number (RGA) number. All returned goods MUST be accompanied by an RGA in order to receive service.

Send warranty card with copy of receipt to :

Appion Inc.
1930 S. Navajo Street
Denver, CO 80223

WARRANTY CARD			
Please complete this and return it within 10 days of purchase with a copy of your sales receipt to validate your warranty			
Name of Purchaser		Company	Phone Number
Street Address		City	State Zip Code
Model	Serial Number	Date of Purchase	Place of Purchase
Please select your primary line of business. (Check all that apply)	How did you learn about our products? (Please only check one)	What features most interested you ? (Check all that apply)	
<input type="checkbox"/> Automotive <input type="checkbox"/> Commercial <input type="checkbox"/> Install Only <input type="checkbox"/> Residential <input type="checkbox"/> Service Only	<input type="checkbox"/> Wholesaler _____ <input type="checkbox"/> Recommended By: _____ <input type="checkbox"/> Magazine <input type="checkbox"/> Mailing <input type="checkbox"/> Newspaper Ad <input type="checkbox"/> Internet	<input type="checkbox"/> High Production <input type="checkbox"/> Low Cost <input type="checkbox"/> Low Maintenance <input type="checkbox"/> Portability <input type="checkbox"/> Quick Delivery <input type="checkbox"/> Other: _____	

Appion Inc.

1930 South Navajo Street

Denver, CO 80223 USA

Phone: 303-937-1580

Fax: 303-937-1599

www.AppionInc.com

sales@AppionInc.com

support@AppionInc.com