

Installation guide

Special springs for liquid level regulating valve

Type PMFL

027R9614

027R9614

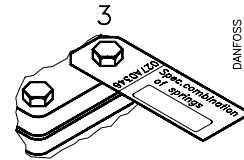
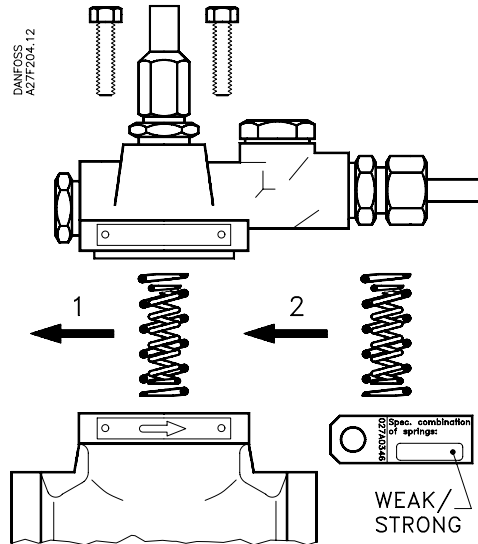

Item.	PMFL	"WEAK"	"STRONG"
		svag/weak/Schwach/faible	kraftig/strong/stark/fort
		Best.nr./Code No./Bestell-Nr./N° de code	
Fjedersæt / skilt Springset / label Federsatz / Schild Jeu de ressorts / plaque	80-1...7	027F0123	027F0118
	125	027F0124	027F0119
	200	027F0125	
	300	027F0126	027F0121

DANSK

Montering

Demonter topdæksel.
 Demonter STANDARD fjedersæt (1).
 Monter spec. fjedersæt (2).
 Monter topdæksel.
 Monter skilt ved topdækselbolt (3).
 Skiltet har betegnelsen WEAK eller STRONG.

ENGLISH

Fitting

Remove top cover.
 Remove STANDARD spring set (1).
 Fit special spring set (2).
 Fit top cover.
 Fit label by top cover bolt (3).
 The label carries the designation WEAK or STRONG.

DEUTSCH

Montage

Kopfdeckel demontieren.
 STANDARD-Federsatz demontieren (1).
 Special-Federsatz montieren (2).
 Kopfdeckel montieren.
 Schild am Bolzen des Kopfdeckels montieren (3).
 Das Schild ist WEAK oder STRONG gekennzeichnet.

FRANÇAIS

Montage

Démonter le couvercle supérieur.
 Sortir le jeu de ressorts STANDARD (1).
 Monter le jeu de ressorts spéciaux (2).
 Remonter le couvercle supérieur.
 Monter la plaque sur le boulon du couvercle supérieur (3).
 La plaque porte la désignation WEAK ou STRONG.